

DIGI TY DESIGNS XLRS SET UP SHEET

Date:	Temp/Air:	Sway Bars: <input type="checkbox"/> Front <input type="checkbox"/> Rear	
Driver:	ESC:	Batteries:	
Track/Race Location:	Servo:	Body:	

Comments:

TRACK CONDITIONS

Traction:
 High Bite Med. Bite Low Bite

Track Difficulty:
 Technical Open Mixed

Track Surface: Carpet Asphalt

TRANSMISSION SETTINGS

<p>Front Differential</p> <input type="checkbox"/> Loose <input type="checkbox"/> Medium <input type="checkbox"/> Medium Tight <input type="checkbox"/> Tight	<p>Rear Differential</p> <input type="checkbox"/> Loose <input type="checkbox"/> Medium <input type="checkbox"/> Medium Tight <input type="checkbox"/> Tight
<input type="checkbox"/> Front One Way	<input type="checkbox"/> Front Solid Diff
Spurgear:	Pinion:
Motor:	Brush:

SHOCK SETTINGS

Shocks: Associated Other_____

Associated Front Springs		Associated Rear Springs	
<input type="checkbox"/> #3941 Green 12 lbs	<input type="checkbox"/> #3941 Green 12 lbs	<input type="checkbox"/> #3941 Green 12 lbs	<input type="checkbox"/> #3941 Green 12 lbs
<input type="checkbox"/> #3942 Silver 14.5 lbs	<input type="checkbox"/> #3942 Silver 14.5 lbs	<input type="checkbox"/> #3942 Silver 14.5 lbs	<input type="checkbox"/> #3942 Silver 14.5 lbs
<input type="checkbox"/> #3943 Blue 17 lbs	<input type="checkbox"/> #3943 Blue 17 lbs	<input type="checkbox"/> #3943 Blue 17 lbs	<input type="checkbox"/> #3943 Blue 17 lbs
<input type="checkbox"/> #3944 Gold 19 lbs	<input type="checkbox"/> #3944 Gold 19 lbs	<input type="checkbox"/> #3944 Gold 19 lbs	<input type="checkbox"/> #3944 Gold 19 lbs
<input type="checkbox"/> #3945 Red 22 lbs	<input type="checkbox"/> #3945 Red 22 lbs	<input type="checkbox"/> #3945 Red 22 lbs	<input type="checkbox"/> #3945 Red 22 lbs
<input type="checkbox"/> #3946 Copper 25 lbs	<input type="checkbox"/> #3946 Copper 25 lbs	<input type="checkbox"/> #3946 Copper 25 lbs	<input type="checkbox"/> #3946 Copper 25 lbs
<input type="checkbox"/> #3947 Purple 30 lbs	<input type="checkbox"/> #3947 Purple 30 lbs	<input type="checkbox"/> #3947 Purple 30 lbs	<input type="checkbox"/> #3947 Purple 30 lbs
<input type="checkbox"/> #3948 Yellow 35 lbs	<input type="checkbox"/> #3948 Yellow 35 lbs	<input type="checkbox"/> #3948 Yellow 35 lbs	<input type="checkbox"/> #3948 Yellow 35 lbs
<input type="checkbox"/> #3949 White 40 lbs	<input type="checkbox"/> #3949 White 40 lbs	<input type="checkbox"/> #3949 White 40 lbs	<input type="checkbox"/> #3949 White 40 lbs

Springs Other F_____R_____

<p>Front Oil:</p> <p>Front Pistons <input type="checkbox"/> #1 <input type="checkbox"/> #2 <input type="checkbox"/> #3</p>	<p>Rear Oil:</p> <p>Rear Pistons <input type="checkbox"/> #1 <input type="checkbox"/> #2 <input type="checkbox"/> #3</p>
--	--

Inner Shock Limiters
 Front: Yes _____ No Rear: Yes _____ No

Outer Shock Limiters
 Front: Yes _____ No Rear: Yes _____ No

TIRES

<p>Foam Tires: <input type="checkbox"/></p> <p>Brand: _____</p> <p>Front Compound: _____</p> <p>Rear Compound: _____</p>	<p>Rubber Tires: <input type="checkbox"/></p> <p>Brand: _____</p> <p>Front Insert: _____</p> <p>Rear Insert: _____</p>
--	--

Left Front

Right Front

Left Rear

Right Rear

Treated Area (Shade): Additive Type: _____

CAR SET UP

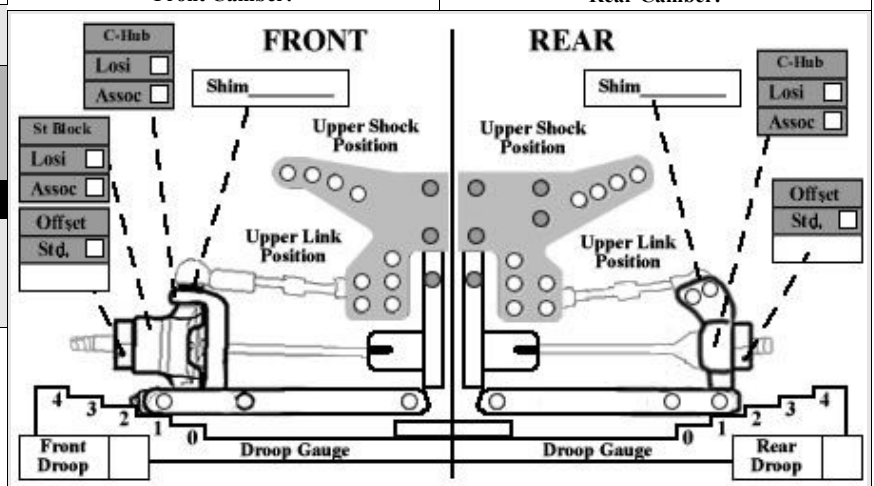
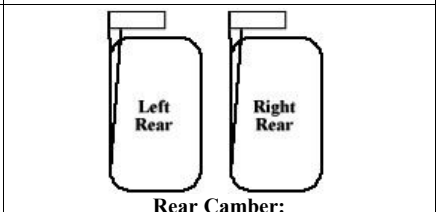
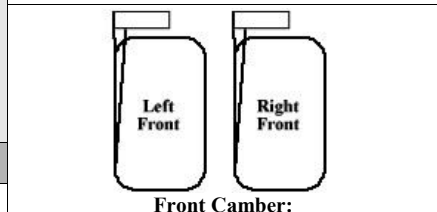
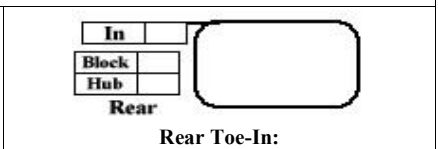
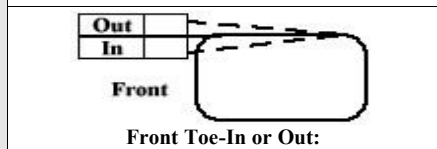
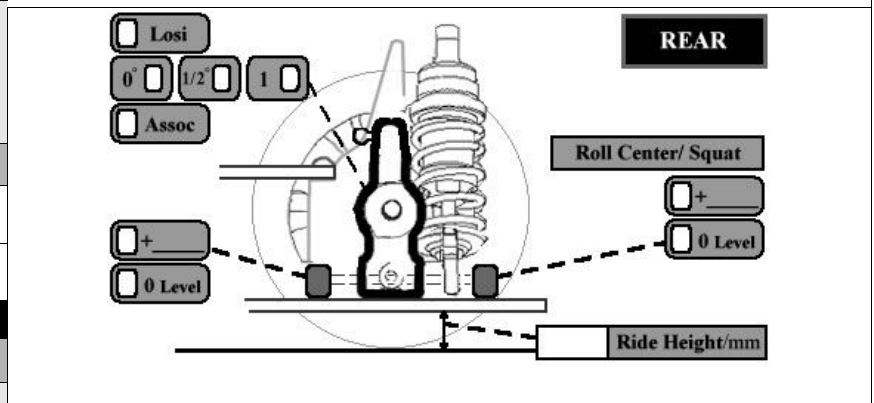
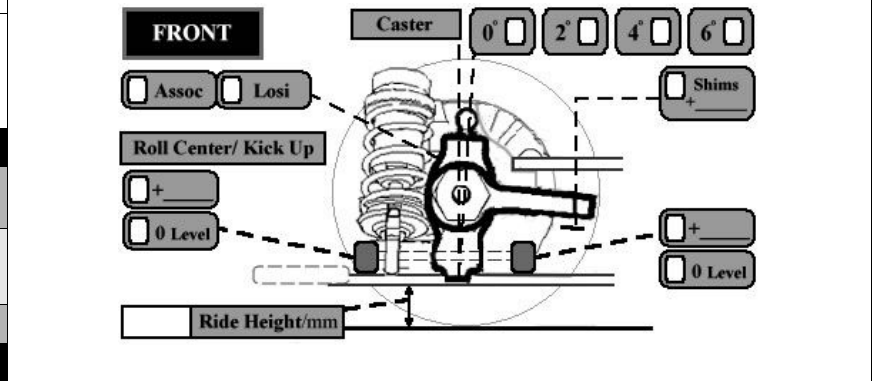

Wheelbase: Long Medium Short